

# RED One Digital Cinema Camera Acquisition Pipeline

specs and workflow subject to change

All formats may be recorded at 10-bit log, 10-bit linear, or 12-bit linear.

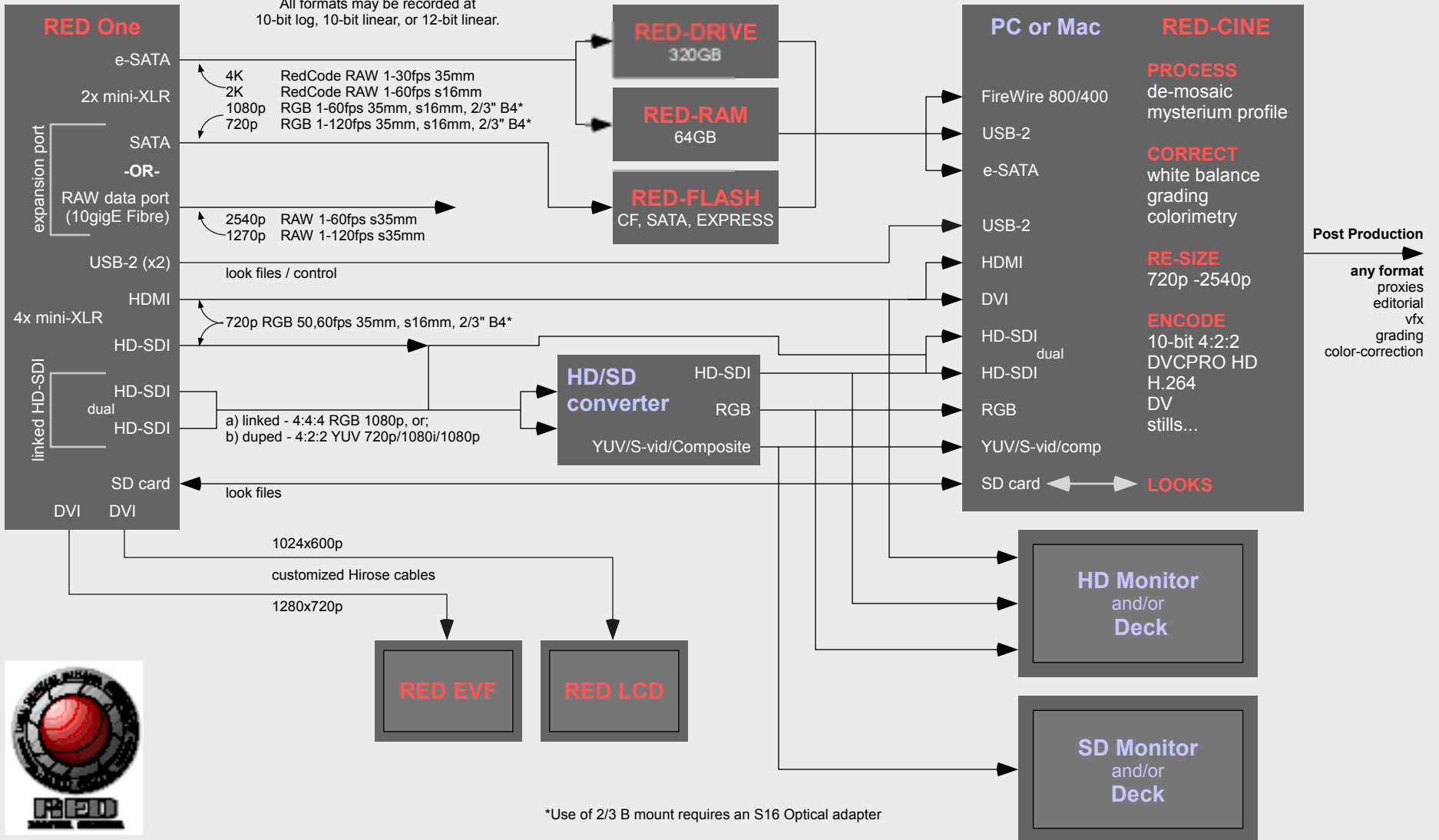

Diagram copyright 2007 Michael Morlan  
Red logo and gear trademark of Red Digital Cinema

\*Use of 2/3 B mount requires an S16 Optical adapter  
\* 23.98fps, 29.97fps & 59.94fps output as well to support the incredibly archaic and FUBAR'ed NTSC Color Standard

v19 2007-03-23